

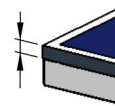

500 X OUTDOOR

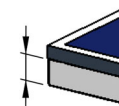

6mm



50mm

**MAT
TOP**



Réf 113100 Outdoor Bleue / Blue

Réf 113400 Outdoor Noire / Black

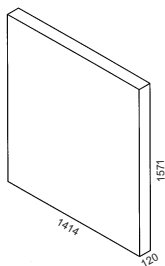

Outdoor: 78 kg

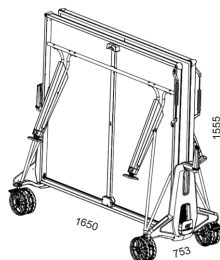

Outdoor: 66 kg







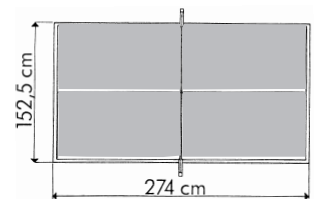

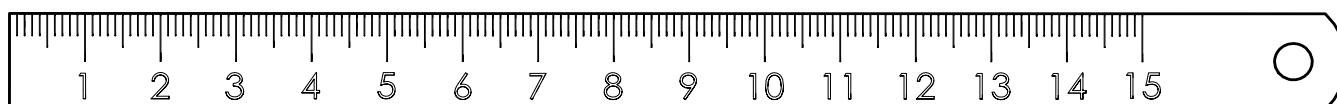
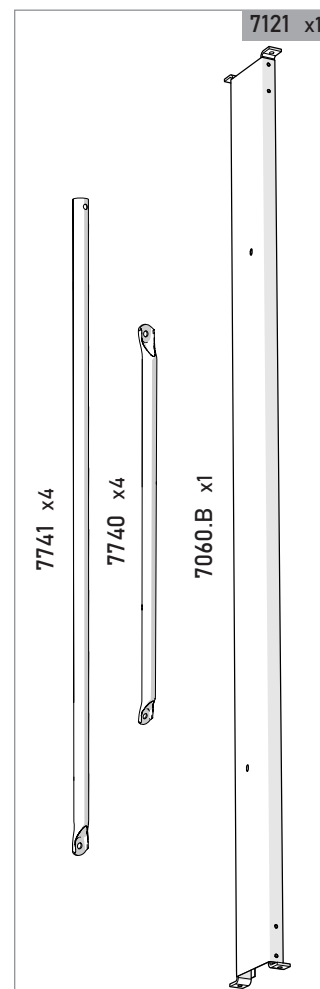
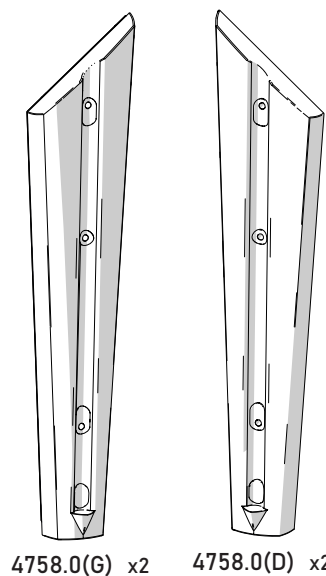
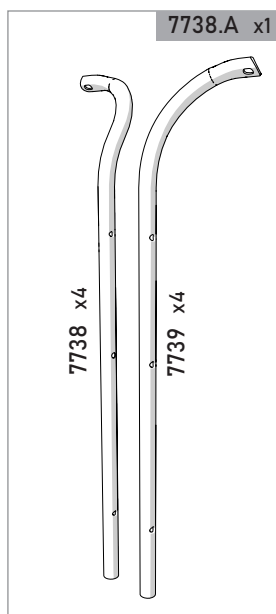
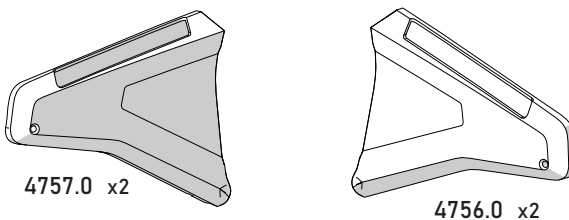
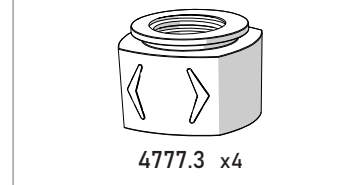
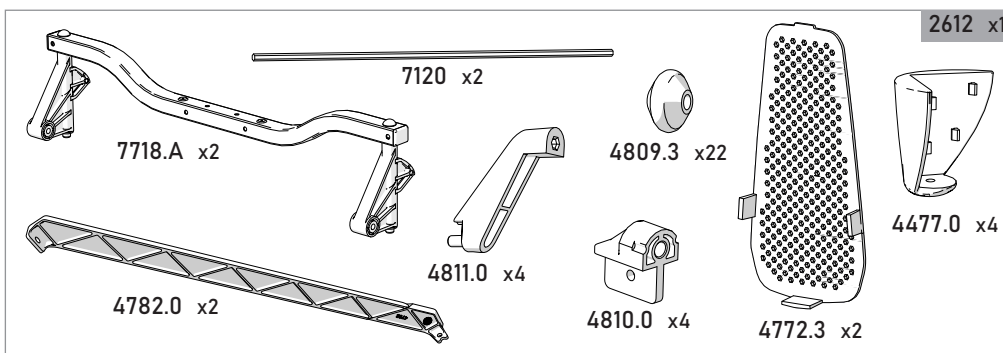
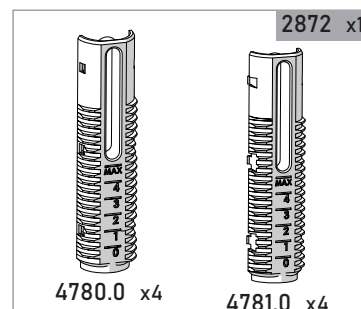
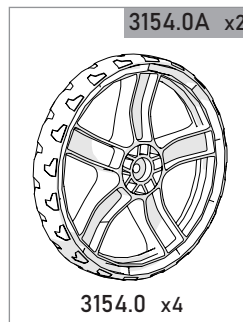
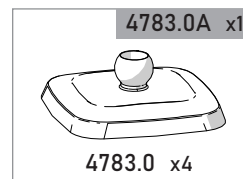
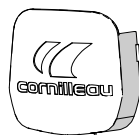
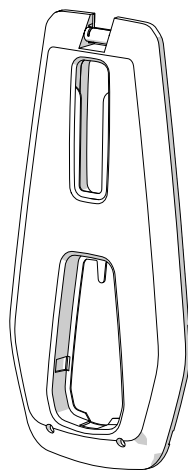
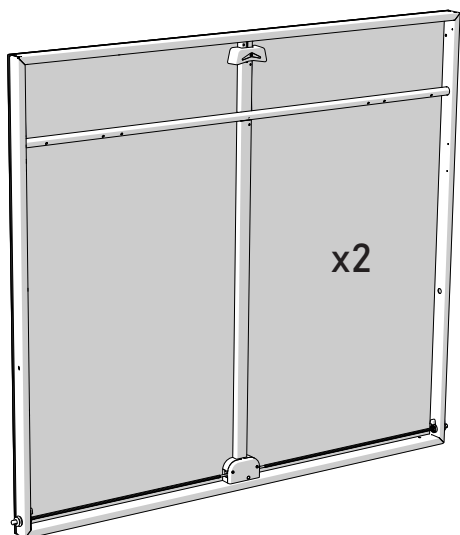







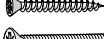
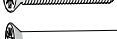

PLAY-BACK

Norme EN 14468-1 (classe C)



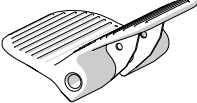
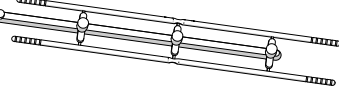

	Dimension	Réf / Qté	Outils
	Ø6	1120 x26	10
	Ø6	1140 x8	10
	Ø8	1121.0 x4	13
	Ø6x15x17	1277 x4	
	Ø6x15x23	1296 x4	
	Ø5x20	1450 x2	PZ2
	Ø4.2x19	1374.0 x8	PZ2
	Ø6x16	1705 x2	10
	Ø3.5x30	1425.0 x2	PZ2
	Ø6x35	1830 x12	PZ3
	Ø6x76	1900 x8	PZ3
	Ø6x80	1838.0 x4	PZ3
	Ø6x90	1843.0 x4	PZ3
	Ø8x90	1034.0 x4	13
	Ø6x110	1844 x4	PZ3
		2355 x1	
		4482.0 x4	
		2204 x2	
		4465.31 x2	
		4794.0 x1	

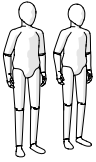

Montage de toutes les phases à 2 personnes. - Assembly during all stages with 2 people. - Für die Montage sind 2 Personen von Vorteil. - Montage van alle fasen met 2 personen. - Il montaggio richiede 2 persone in tutte le fasi. - Montaje de todas las fases a 2 personas. - Montagem de todas as fases com 2 pessoas - Συναρμολόγηση όλων των φάσεων με 2 άτομα - Minden összeszerelési szakaszt 2 személynek kell elvégezni - Montaż wszystkich etapów przez 2 osoby - Toate etapele de montare trebuie realizate de către 2 persoane - Všechny montážní kroky musejí provádět 2 osoby. - Сборка на всех стадиях должна производиться 2 лицами.



PZ 2
PZ 3

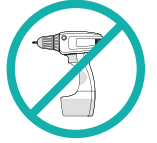

Laisser du jeu - Leave a little play - Es ist ein Spiel zu lassen - Laat wat speling - Lasciare del gioco - Dejar holgura - Deixar folga - Λασκάρετε - Hagyjon egy kis játékot - Pozostaw przerwę - Abandonarea/Cedarea jocului - Nechejte dostatečnou vůli. - Оставить зазор



Serrer - Tighten - Pressen - Aandraaien - Stringere - Apretar - Aperte - ελέγχο αυστηρά, καταστέλλω - Meg kell - Jedna śruba - Stoarceți - Jeden šroub - Сожмите



Reperer l'opération (x) fois - Repeat operation (x) times - Wiederholen Sie diesen Vorgang (x) mal - deze handling (x) maal herhalen - Operazione da ripetere (x) volte - Repetir la operacion (x) veces - Repetir a operação (x) vezes - Επαναλαμβάνετε τη πράξη (x) φορές - Ismétélje meg a műveletet (x) alkalommal - Powtórz czynność (x) razy - Repetați operațiunea de (x) ori - Operaci (x) krát opakujte. - Повторить операцию (x) раз

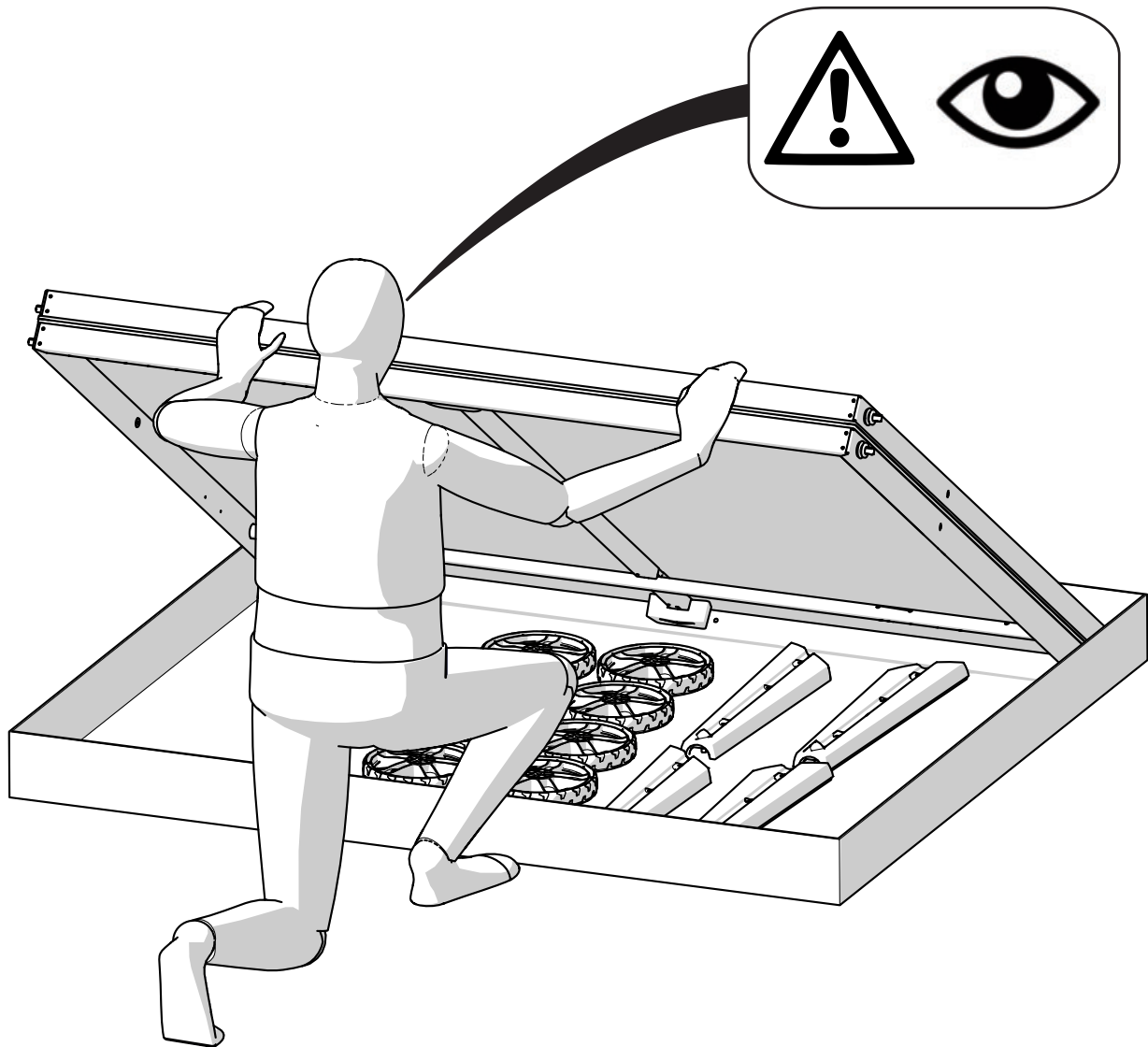

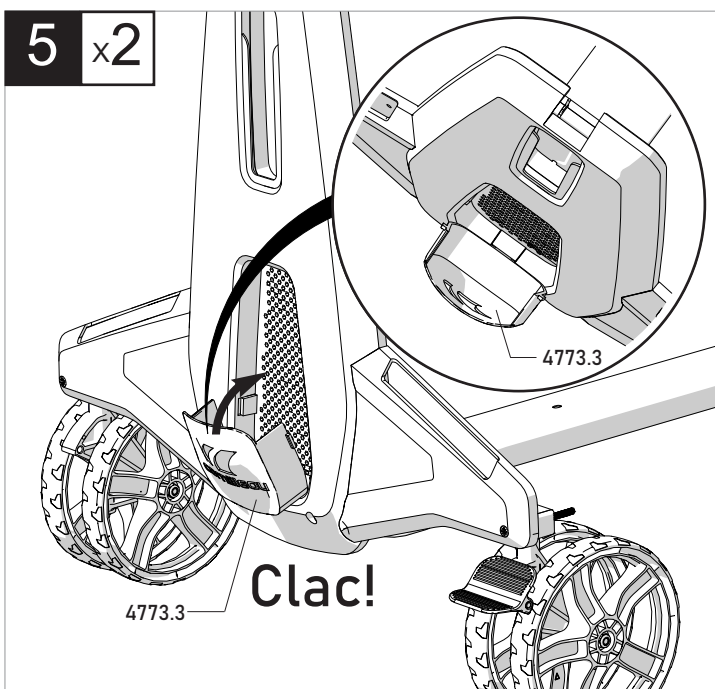
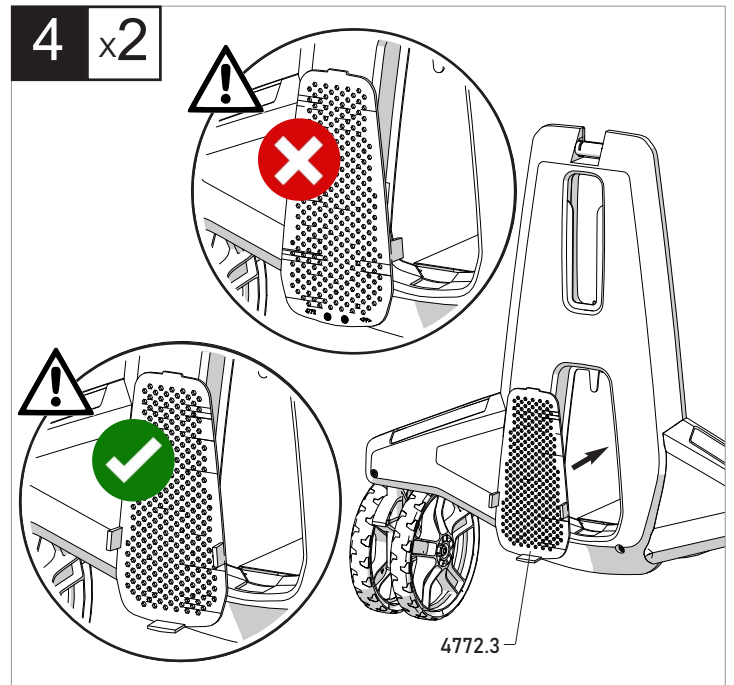
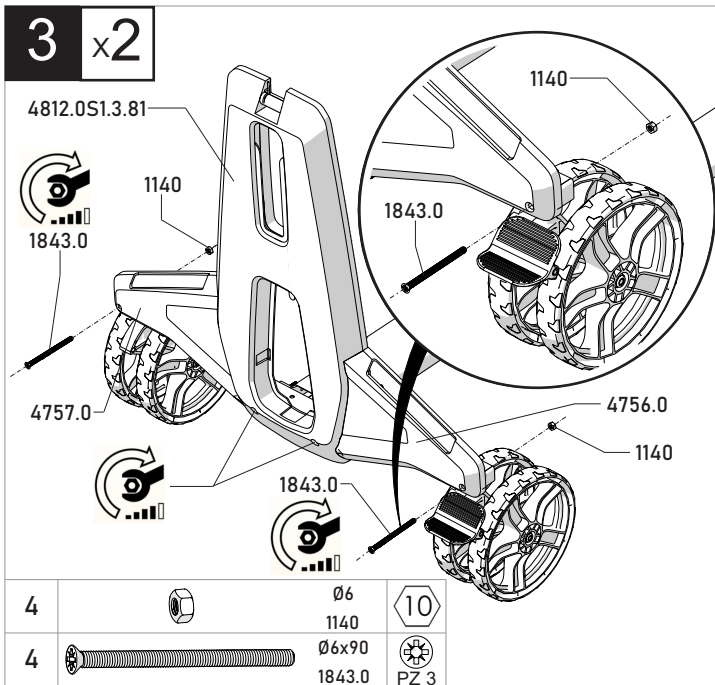
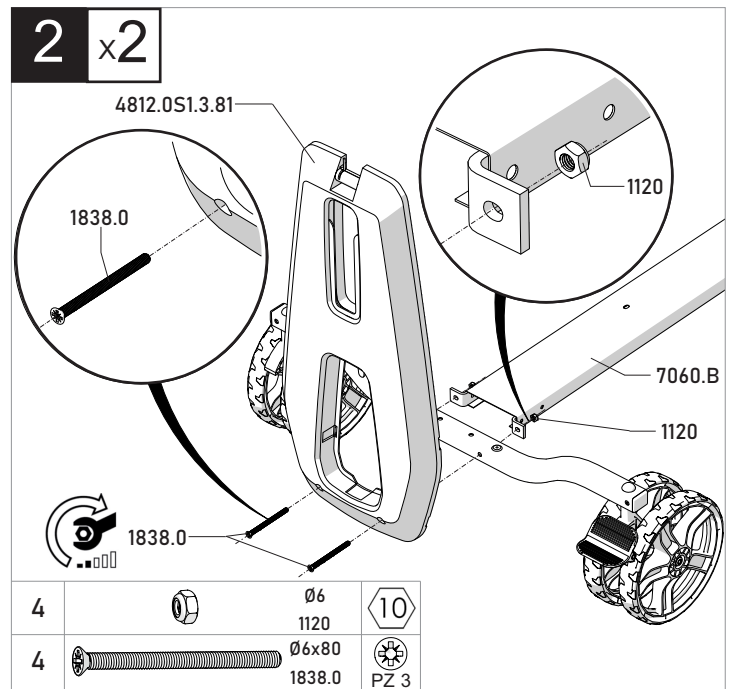
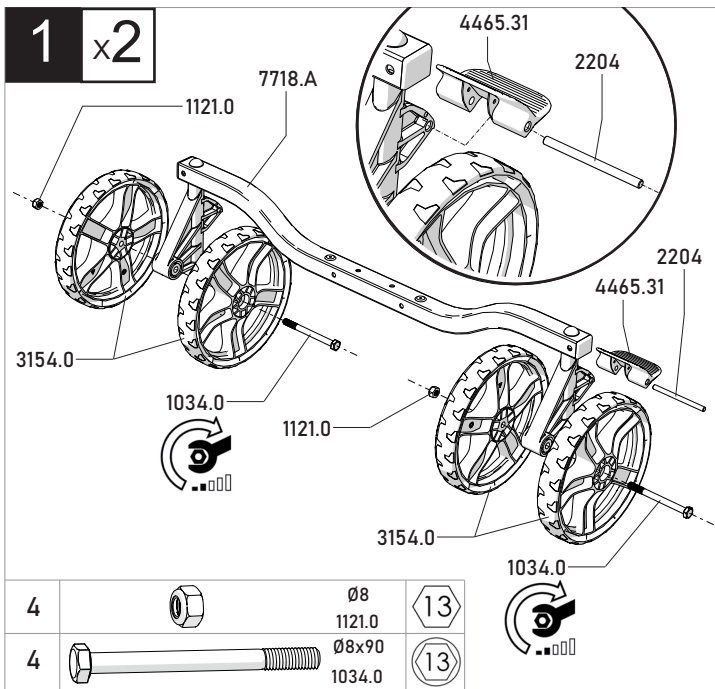

6 x1

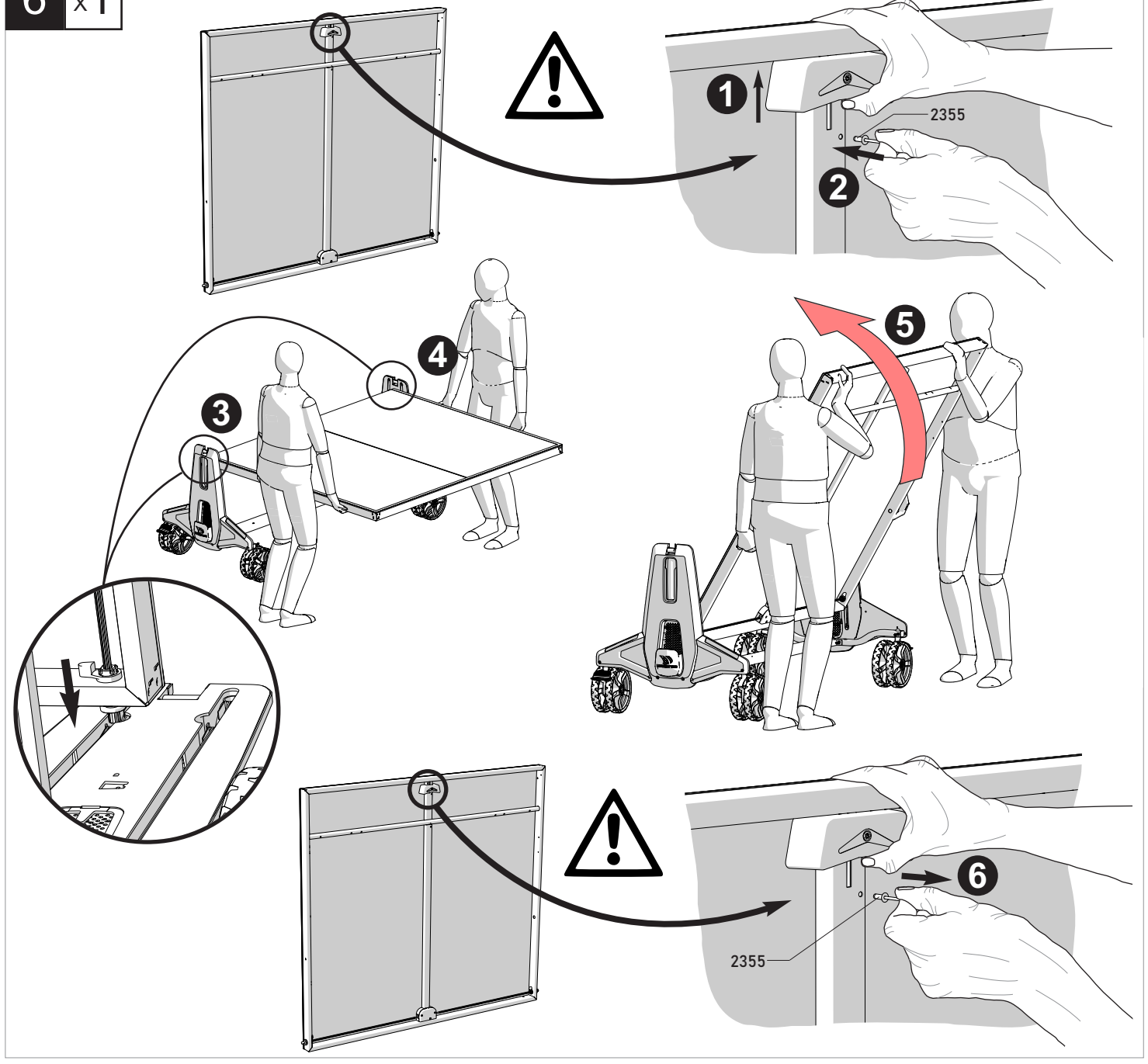

7 x2

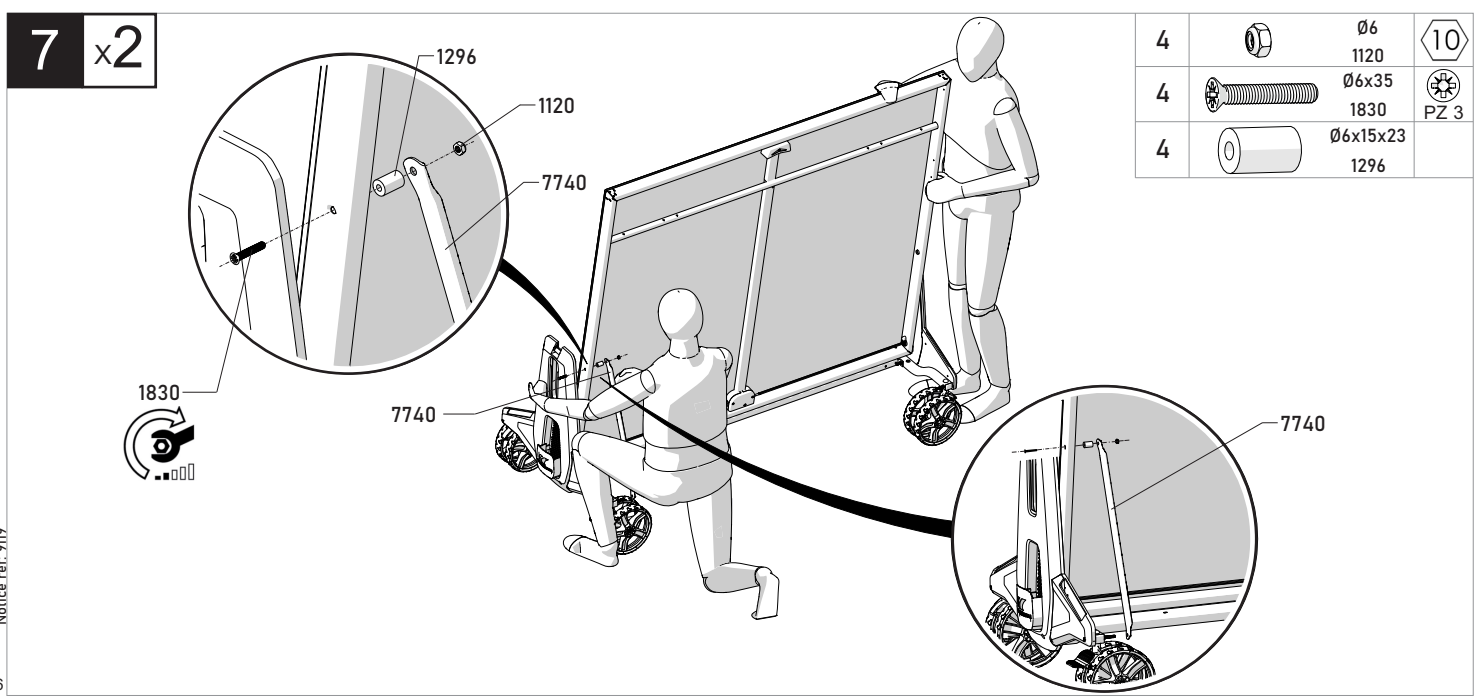

8 x2

7740 1277 1120 7741 7740 7741 1120 1277

4		Ø6 1120		10
4		Ø6x15x17 1277		

6 x1 7 x2 8 x2

N°2

x2

9 x4

7741 4482.0

10 x2

4810.0 4811.0 7120 4809.3 4811.0 4810.0

11 x2

1374.0 1374.0 1374.0 1374.0

4		Ø4.2x19 1374.0		PZ 2
---	--	-------------------	--	------

12 x4

4780.0 4781.0 4783.0

Clac !

13 x4

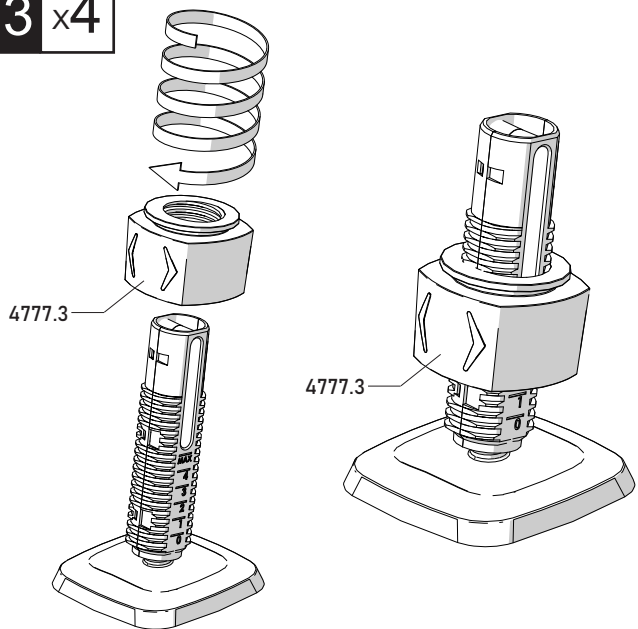

14 x4

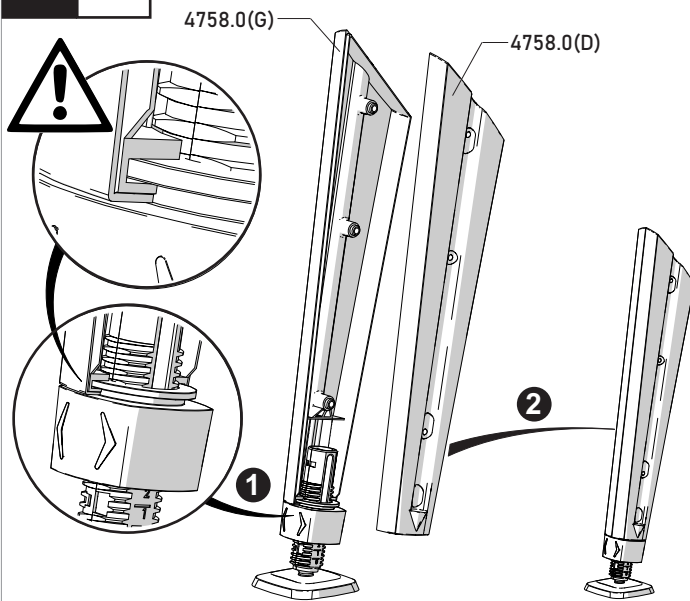

15 x2

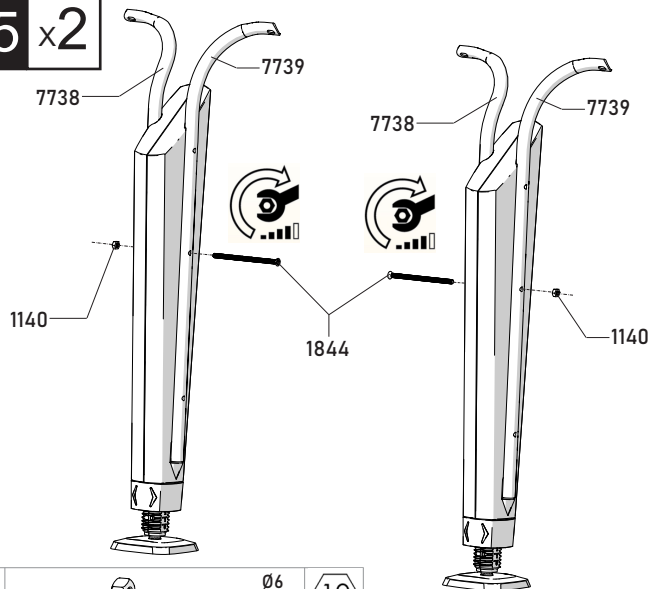

4		Ø6 1140	
4		Ø6x110 1844	

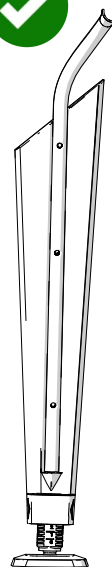

16 x4

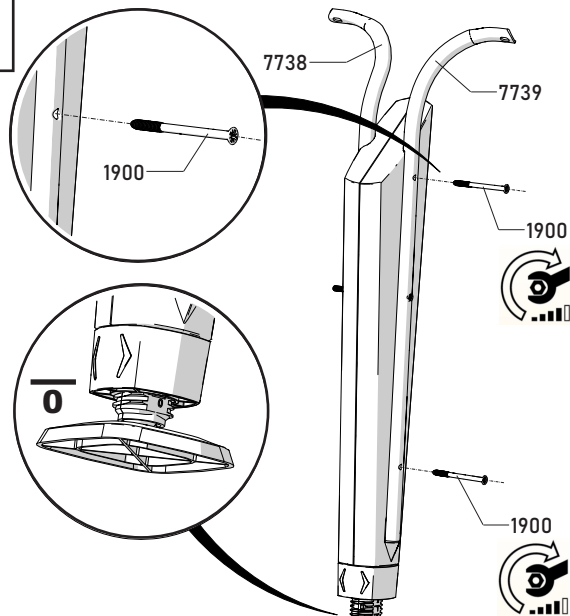

8		Ø6x76 1900	
---	--	---------------	--

17 x4

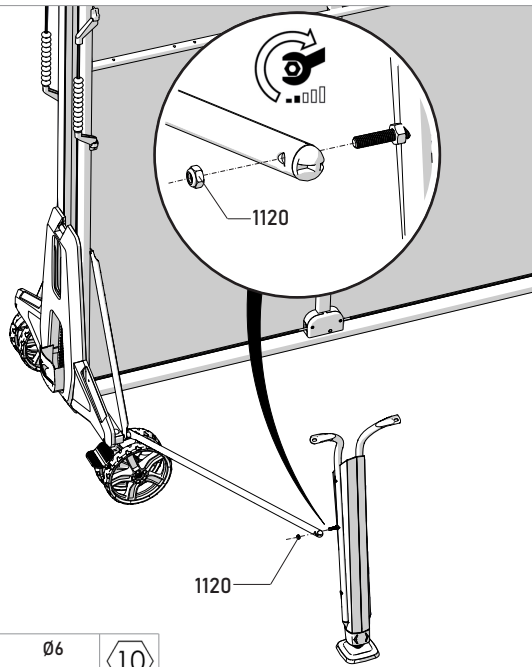

4



Ø6
1120

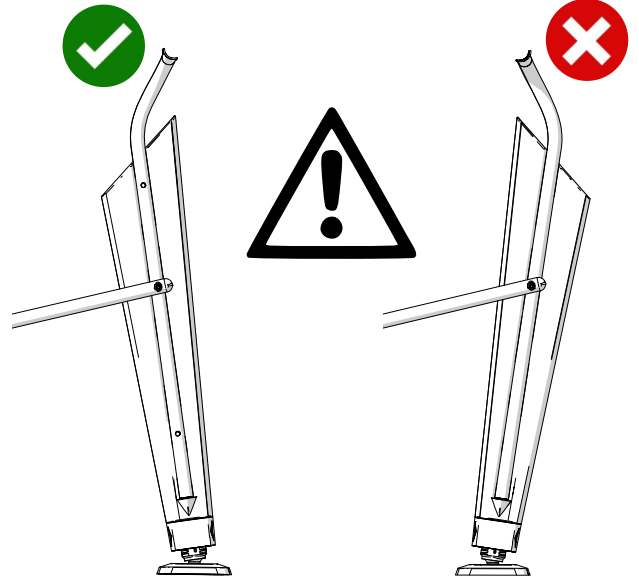

18 x4

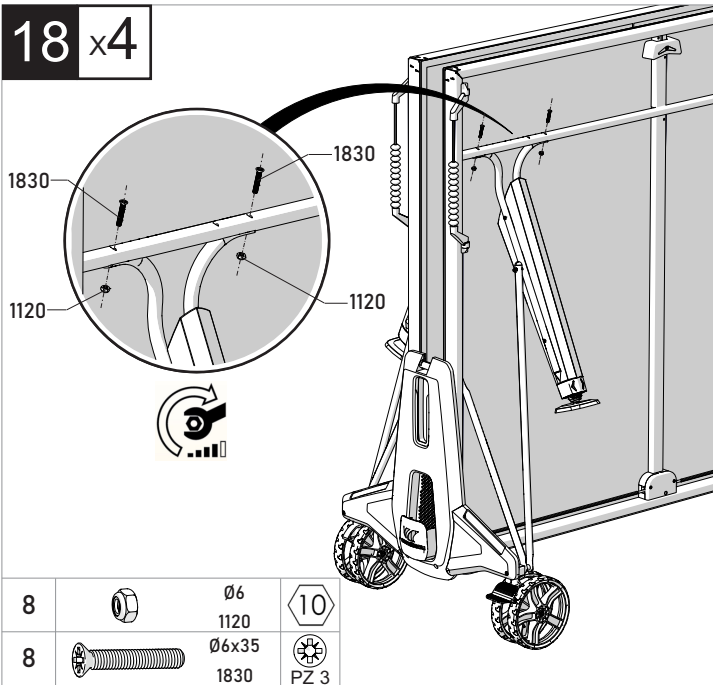

8



Ø6
1120



8



Ø6x35
1830



19 x2

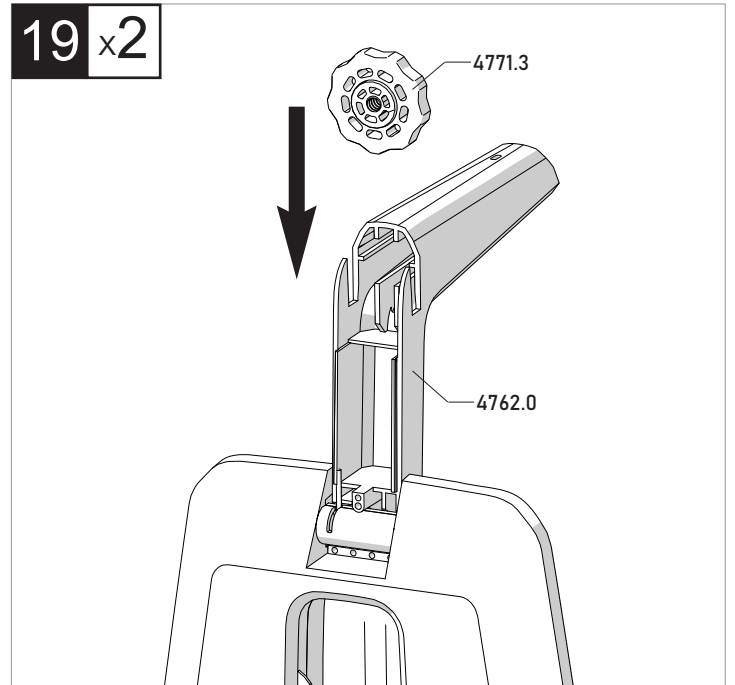

20 x2

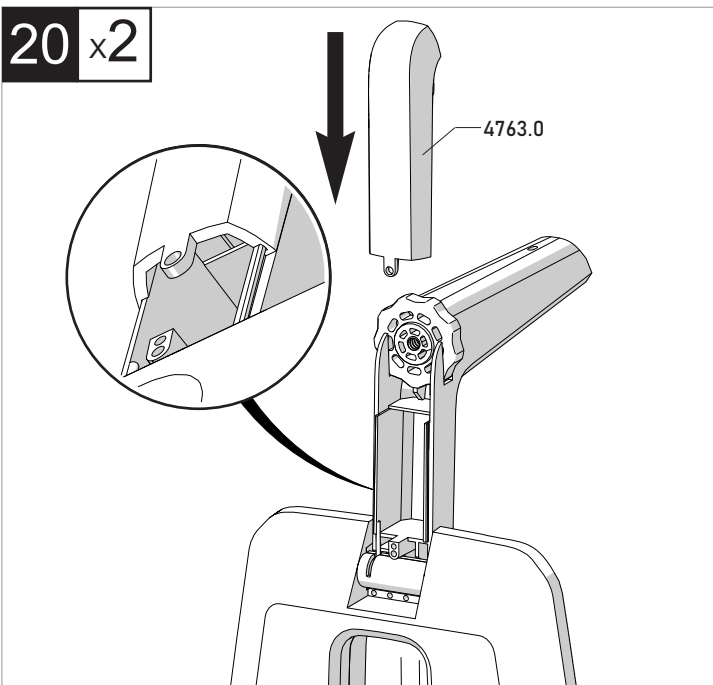

21 x2

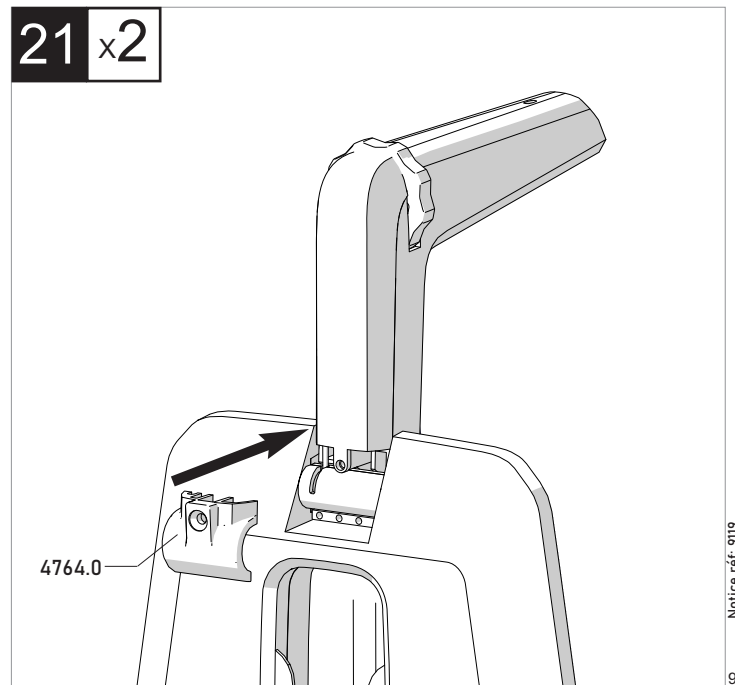

22 x2



1425.0

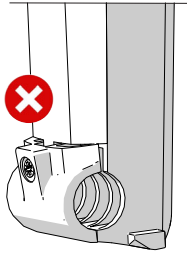
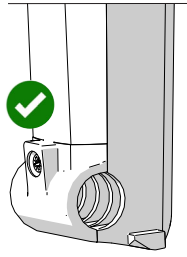

2

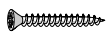

Ø3.5x30
1425.0



PZ 2

24 x4

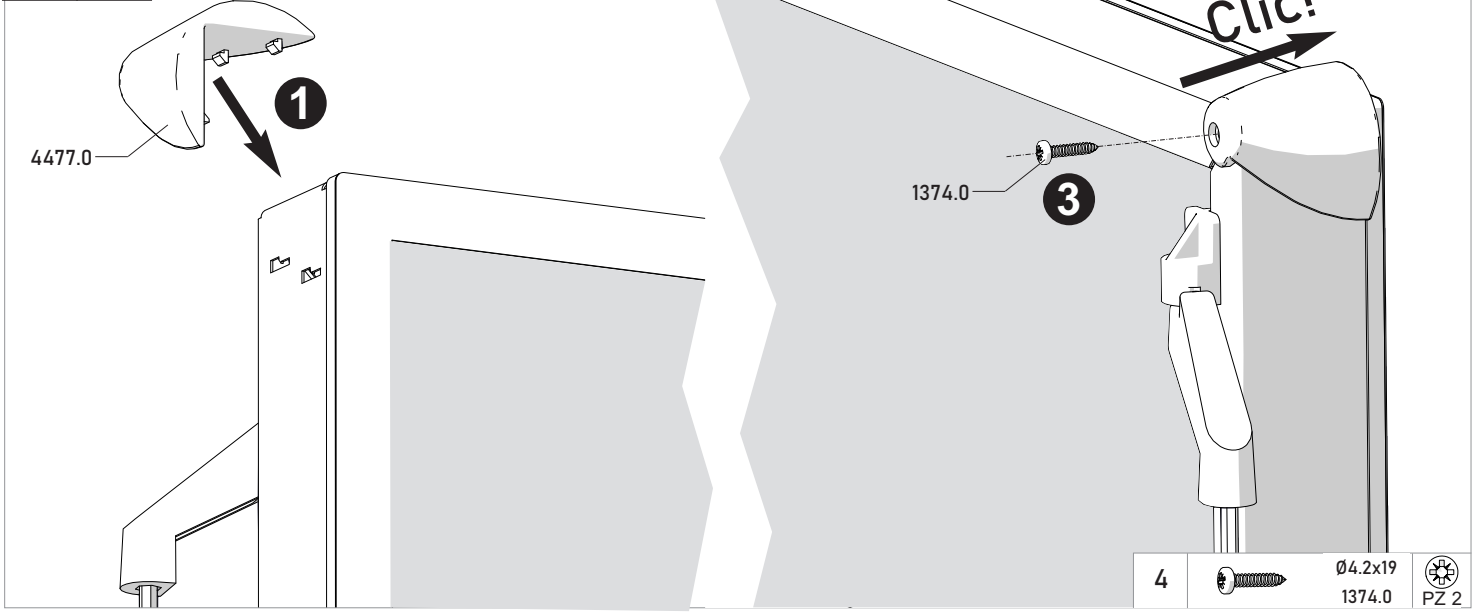

4		Ø4.2x19 1374.0	
---	--	-------------------	--

25 x2

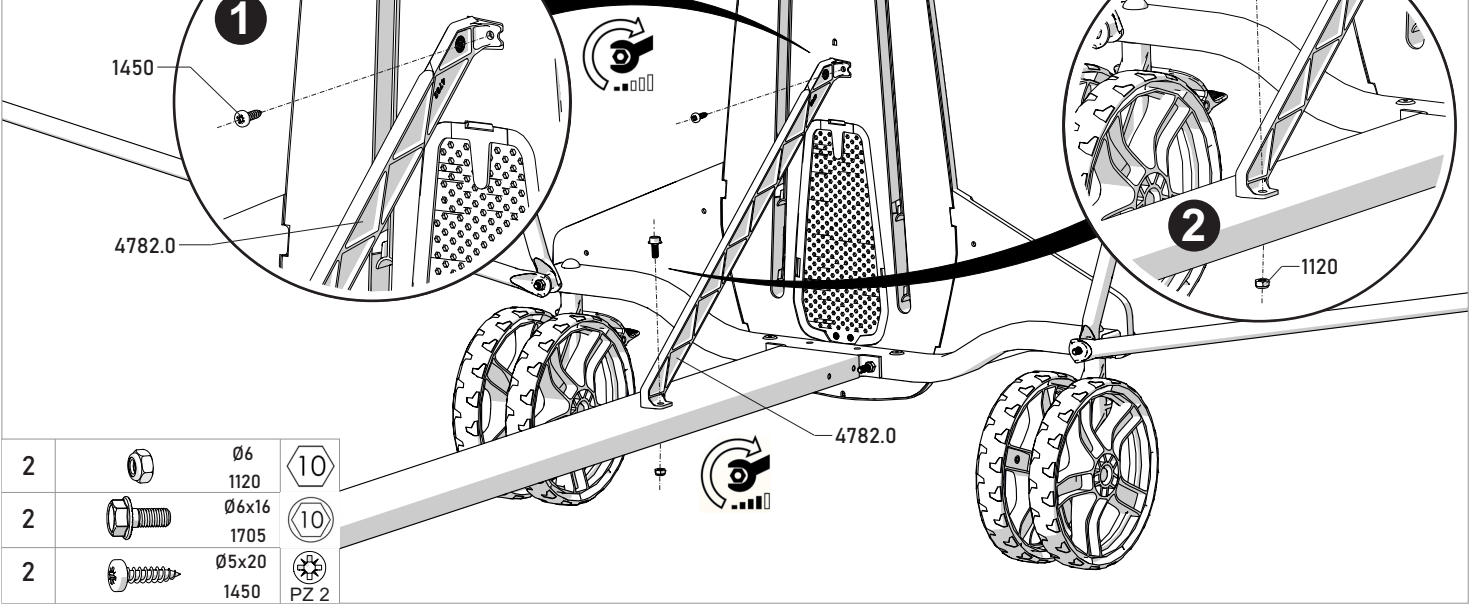

2		Ø6 1120	
2		Ø6x16 1705	
2		Ø5x20 1450	

26 x2

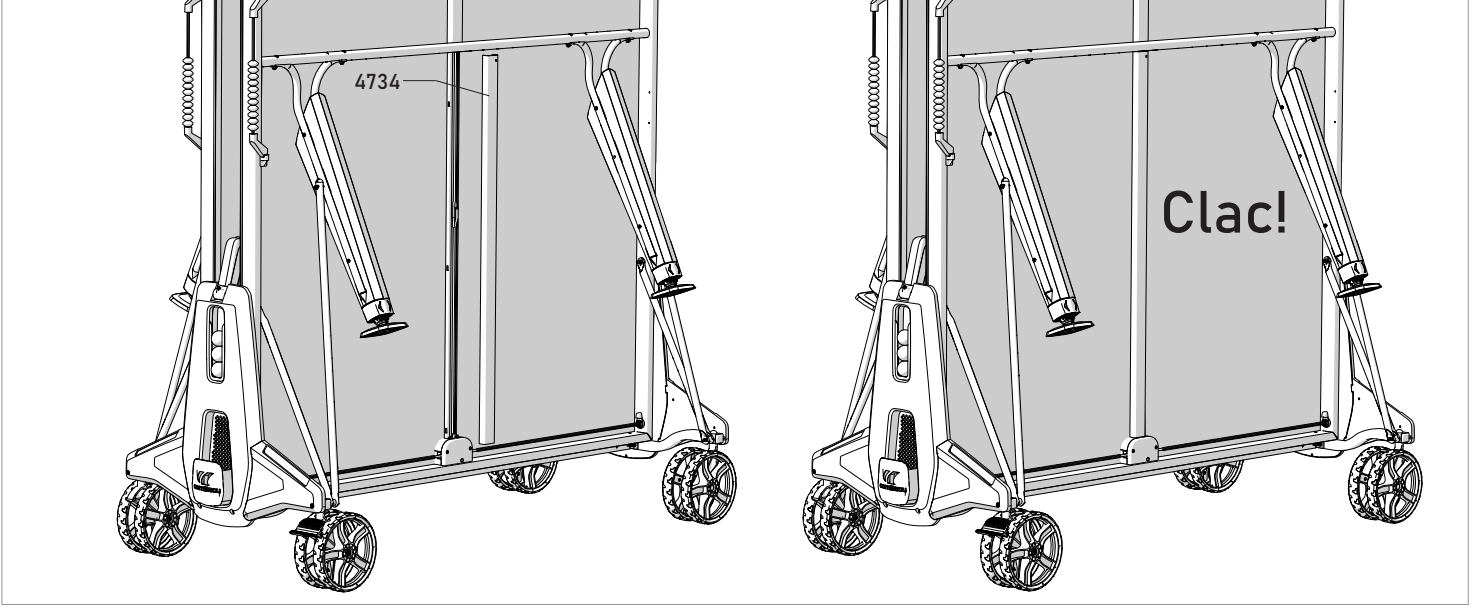

Remise en place du système de verrouillage en cas de dysfonctionnement - Repair of the locking system in case of malfunction - Öffnung des Verriegelungssystems für Reparatur - Reparatie (aleen indien) - Rimessa in ordine del sistema di chiusura in caso di malfunzionamento - Reparaci n (solamente si es necesario) - Coloca o em posi o do sistema de bloqueio no caso de disfun o - Ξαναθ ετε στη θ εση το σ στημα κλειδ ματος σε περ πτωση δυσλειτουργ ας - A z rrendszer helyre ll t sa m k d si hiba eset n - Przywr cenie systemu blokady w przypadku niewłaściwego działania - Reglarea sistemului de blocare  n caz de disfunc ie - Nasazen  zajišťovac ho syst mu v p rpad  špatn ho fungov n  stolu - Установить систему блокировки в случае функционального сбоя.

