

Cornilleau PARK Permanent Outdoor Table Tennis Table – Fixing Options

Table Assembly Video: <https://www.youtube.com/watch?v=7fJleQz9ro8&t=23s>

From: 4mins 30 sec the fixing options are featured

1. If siting on a concrete base, the table can be secured to the ground using fixings that go through the holes in the feet of the table. The grounds team would need to determine suitable fixings based on the depth of the concrete base.

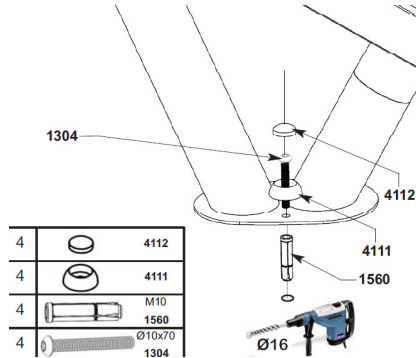

2. If siting on tarmac or any kind of safety surface, our recommendation is to not secure the table to the ground but to add sand trays to the table. These work by increasing the overall weight of the table from 160kg up to a maximum of 360kg depending on the quantity of sand used. We will fit the sand trays as part of the assembly process but the customer needs to supply the sand and have it available at the time of assembly. The capacity is approx 0.133m³ / 200kg of sand.



3. If siting on grass, the anchorage kit is the best option of securing the table to the ground.

